

## APA Program Report 2009

### 1. Recent Trends in Mutual Agreement Procedures (MAP)

The number of MAP cases has increased in recent years, with more than 90% of these cases being related to transfer pricing. In particular, the number of Bilateral Advance Pricing Arrangements (BAPA; an APA accompanied by MAP) accounts for the majority of the increase in the number of MAP cases.

During the 2008 business year (July 2008 until June 2009), the National Tax Agency (NTA) received 174 MAP cases, of which 130 were BAPA. Compared to the statistics a decade ago (1998 business year), the number of MAP cases has increased by a factor of approximately four, while the number of BAPA cases has increased by a factor of approximately ten.

Chart 1 below indicates the trends in the number of MAP cases and BAPA cases over the past decade.

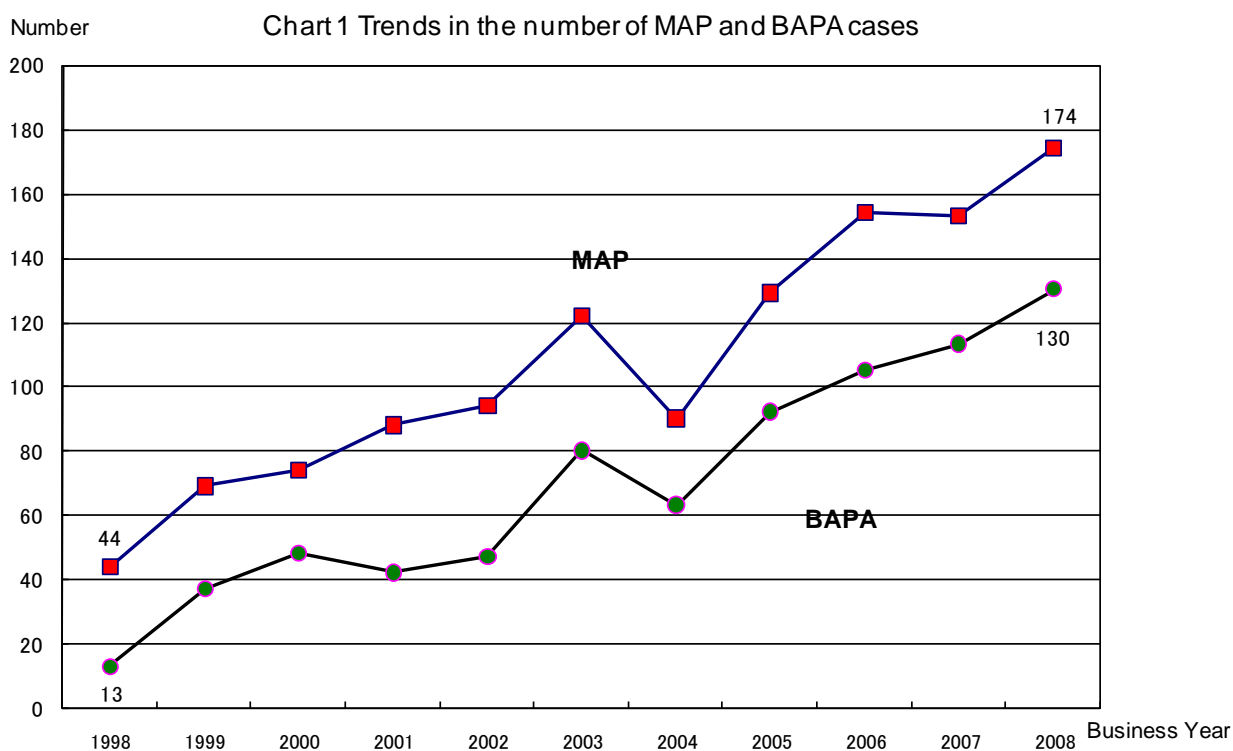

(Notes)

- 1 The business year runs from the beginning of July until the end of June in the following year.
- 2 The number of MAP cases consists of both cases in which the NTA received MAP requests from taxpayers in Japan, and cases in which the NTA received MAP requests from foreign tax authorities.
- 3 MAP cases on compensating adjustments and amendments to a previously agreed APA are counted in renegotiation years.

## 2. Summary of the BAPA program update

### a. Number of BAPA cases disposed of in the 2008 business year

The number of BAPA cases disposed of in the 2008 business year was 91. (Details are shown in Charts 2 through 5 below.)

### b. Number of BAPA cases disposed of by industry

The number of BAPA cases disposed of, as categorized by the taxpayer's industry, is shown in Chart 2 below.

In the 2008 business year, the number of cases for manufacturing companies was 64, while that for wholesale/retail companies was 23.

Further details for each industry are shown in Chart 2-2 below.

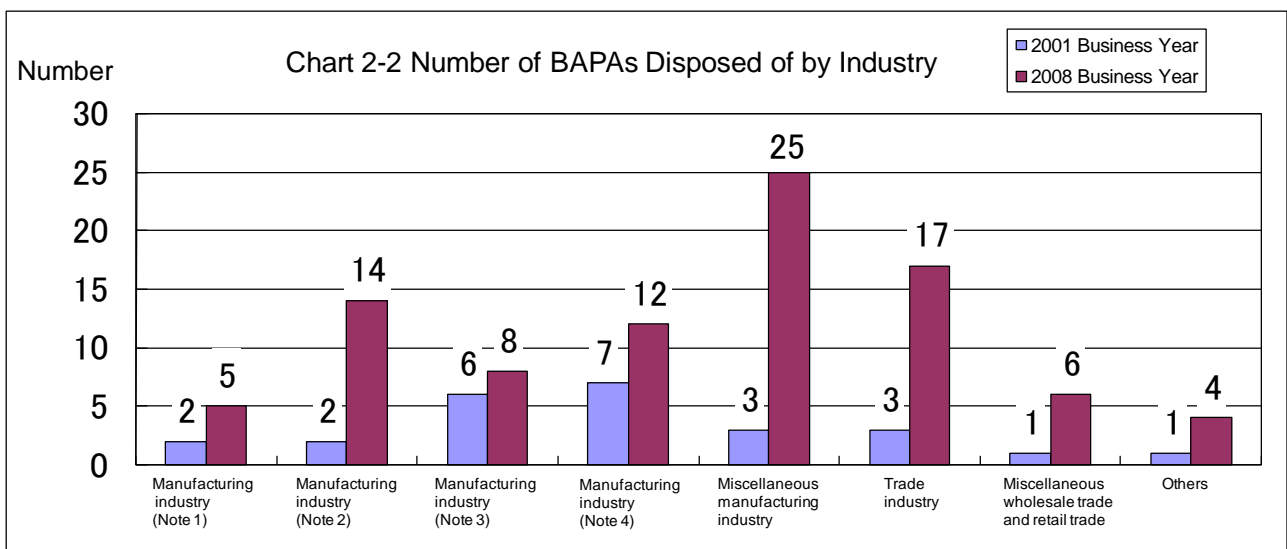
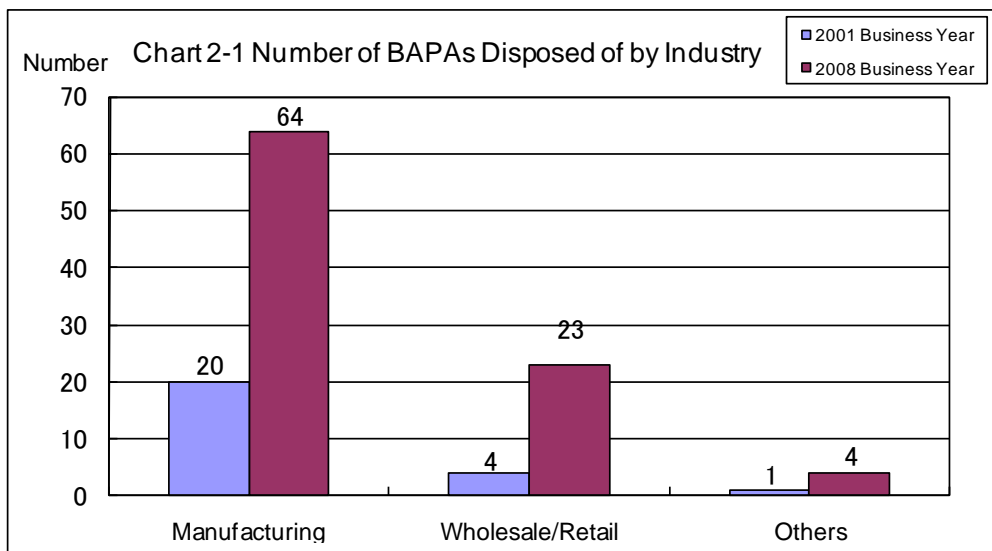

(Notes)

- 1 Manufacture of household electrical appliances and electric bulbs
- 2 Manufacture of transportation equipment
- 3 Manufacture of industrial electrical apparatus
- 4 Manufacture of machinery

c. Number of BAPA cases disposed of by transaction type

The number of BAPA cases disposed of, as categorized by transaction type is shown in Chart 3 below.

In the 2008 business year, the number of Tangible Property Transactions was 82, the number of Provision of Services cases was 31, and the number of Intangible Property Transactions was 36.

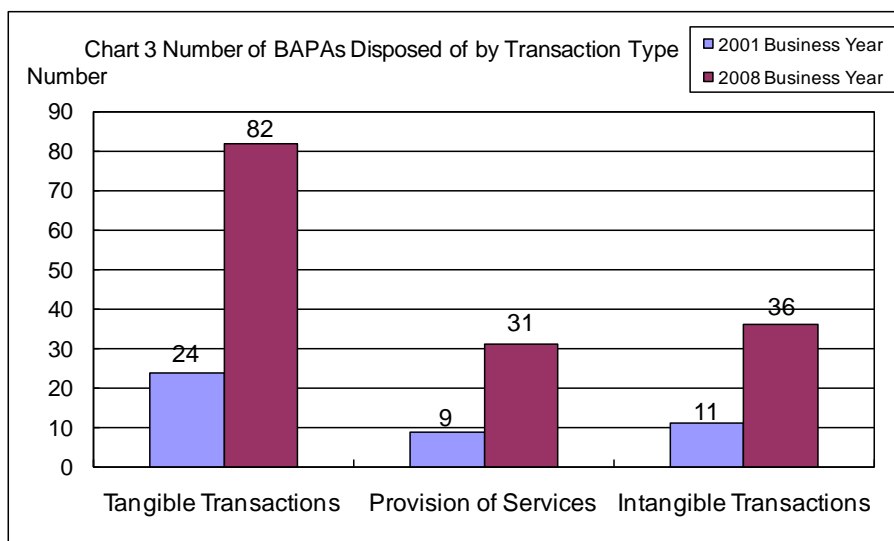

(Note)

Cases including different types of transactions are counted more than once according to the transactions involved, and the number of transactions is different from the number of BAPA cases.

d. Number of BAPA cases disposed of by transfer pricing method

The number of BAPA cases disposed of, as categorized by the transfer pricing method, is shown in Chart 4 below.

In the 2008 business year, the number of TNMM (Transactional Net Margin Method, introduced in 2004) cases was remarkably high.

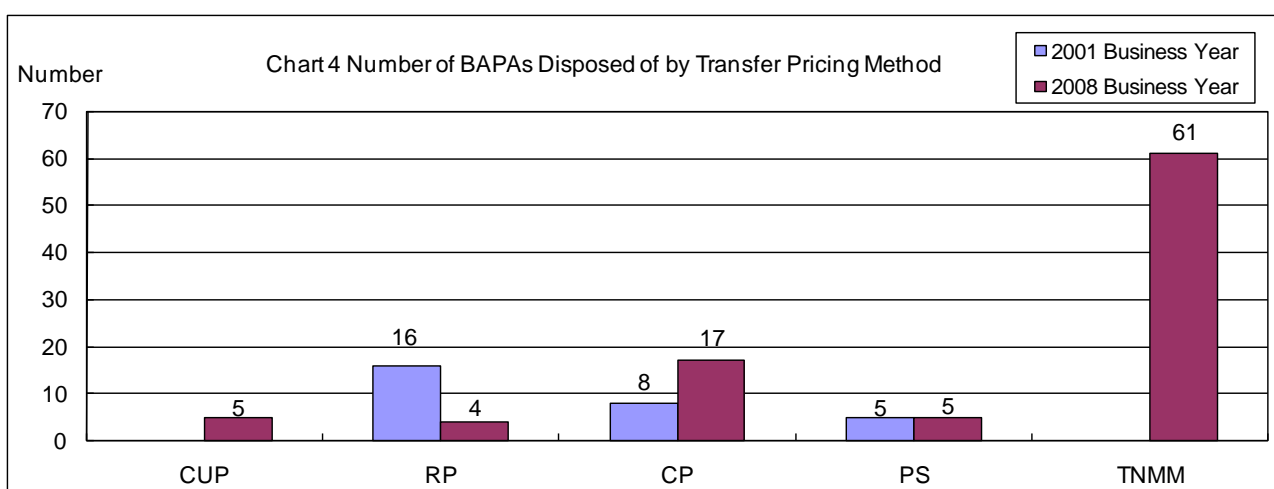

(Note)

In some cases, more than one transfer pricing method is applied in accordance with the transactions involved, and the number of transfer pricing methods is different from the number of BAPA.

e. Number of BAPA cases disposed of by region

The number of BAPA cases disposed of, as categorized by region is shown in Chart 5 below.

Although the number of BAPA cases with the U.S.A. and Australia has traditionally accounted for a large share of the total, the number of BAPA cases with Asian countries is increasing. The number of BAPA cases involving these countries is expected to increase further in the future.

In the 1998 business year (ten years ago), the number of countries with which the NTA was involved in BAPA negotiations was 4; this number has increased to 18 in the 2008 business year.

(Note)

The number of countries with which the NTA was negotiating one or more BAPA cases at the end of the 2008 business year is shown in Attachment 1 “Partner Countries for the Mutual Agreement Procedure”.

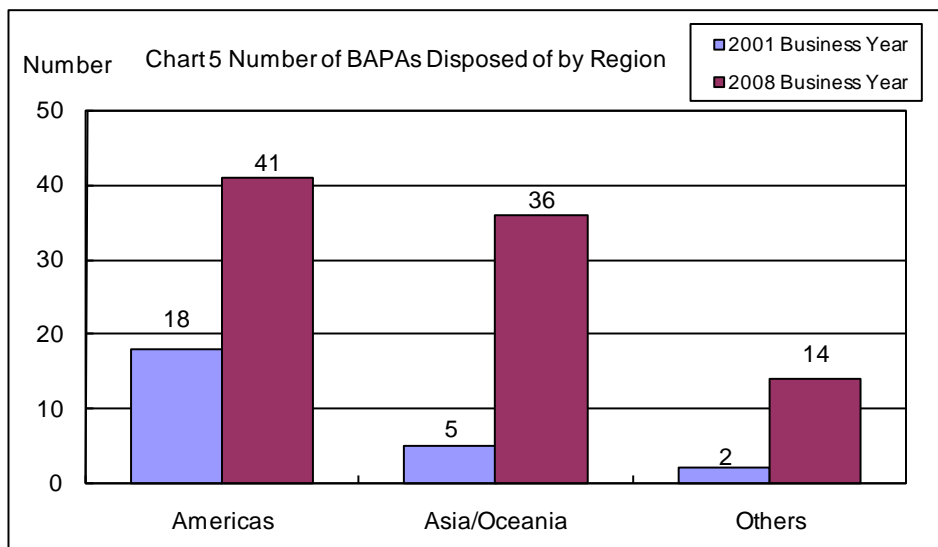

(Note)

The treaty partners from which the NTA received the largest numbers of BAPA cases in the 2008 business year were : ①U.S.A. ②Australia ③Korea.

f. Average time spent on a BAPA case

Although it varies substantially according to the nature of each case( e.g., whether the case is new or a renewal, etc.), the average time spent on a BAPA case in the 2008 business year was 23.7 months .

# Partner Countries of Mutual Agreement Procedure

(Attachment 1)

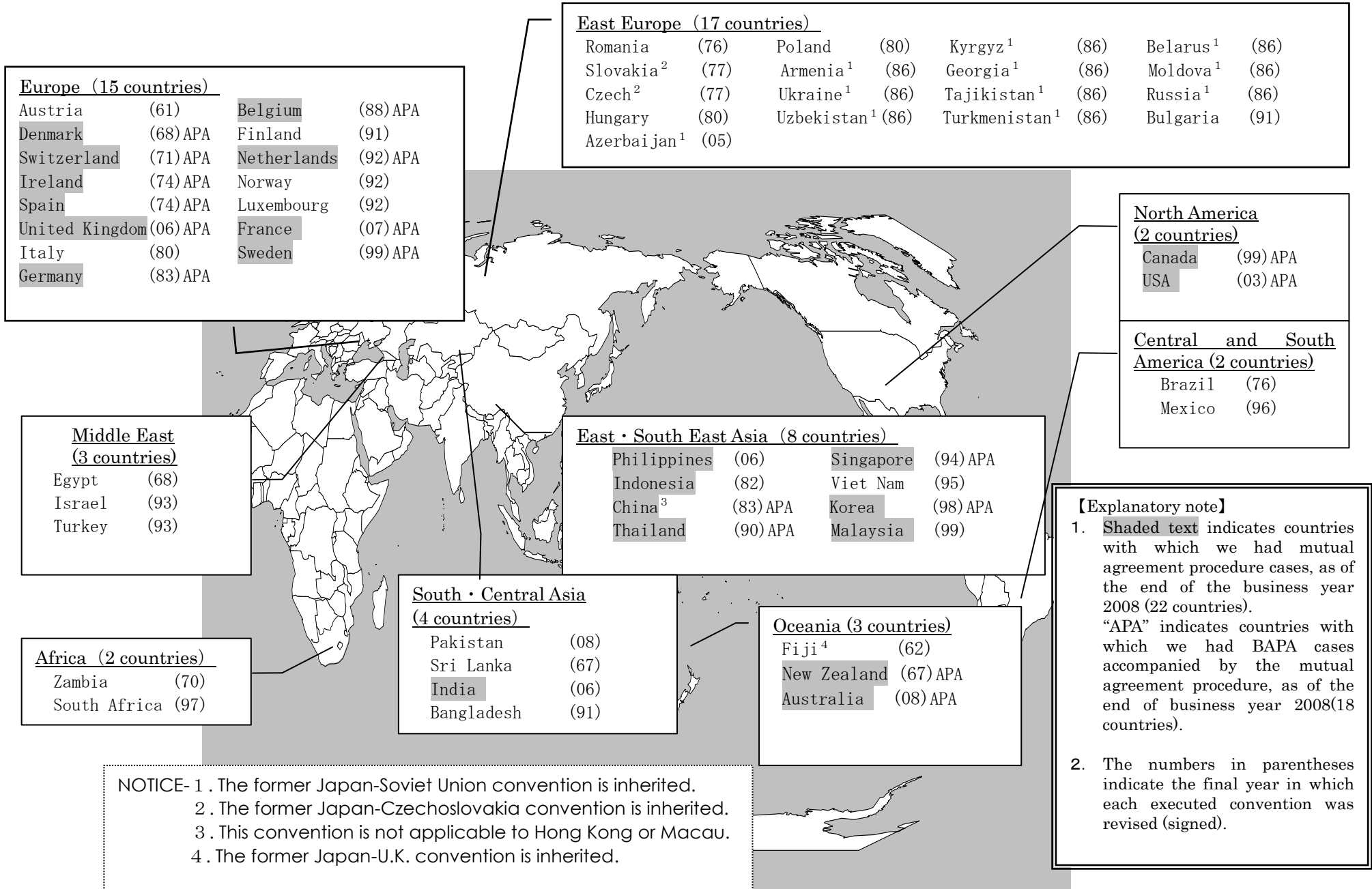

NOTICE- 1. The former Japan-Soviet Union convention is inherited.  
 2. The former Japan-Czechoslovakia convention is inherited.  
 3. This convention is not applicable to Hong Kong or Macau.  
 4. The former Japan-U.K. convention is inherited.

**【Explanatory note】**  
 1. Shaded text indicates countries with which we had mutual agreement procedure cases, as of the end of the business year 2008 (22 countries). “APA” indicates countries with which we had BAPA cases accompanied by the mutual agreement procedure, as of the end of business year 2008(18 countries).  
 2. The numbers in parentheses indicate the final year in which each executed convention was revised (signed).

### Summary of MAP Statistics

Business Year		BAPA	Transfer Pricing Taxation	Others	Total
2006	Cases Received	105	35	14	154
	Cases Disposed of	84	16	15	115
	Cases Carried Over	191	59	26	276
2007	Cases Received	113	31	9	153
	Cases Disposed of	82	33	10	125
	Cases Carried Over	222	57	25	304
2008	Cases Received	130	30	14	174
	Cases Disposed of	91	23	13	127
	Cases Carried Over	261	64	26	351

(Notes)

- 1 The business year runs from the beginning of July until the end of June in the following year.
- 2 The number of MAP cases consists of both cases in which the NTA received MAP requests from taxpayers in Japan, and cases in which the NTA received MAP requests from foreign tax authorities.
- 3 MAP cases on compensating adjustments and amendments to a previously agreed APA are counted in renegotiation years.

## Outline of APA (Reference)

## Contents

1	Introduction .....	1
2	What is an Advance Pricing Arrangement (APA)? .....	2
3	The History of APAs in Japan and around the World .....	3
4	International Efforts for making the MAP Guidance, etc. ....	4
5	Overview of APA in Japan .....	5
	(1) Definition of APA	
	(2) Relationship between APA and MAP	
	(3) Relationship between APA and Transfer Pricing Examination	
	(4) Request and Review Procedures	
	(5) Review of APA Request	
	(6) Effects of APA	
	(7) Examination of Compliance Conditions	
	(8) Compensating Adjustments	
	(9) Revision, Cancellation, and Renewal of APA	
	(10) Rollback	
	(11) Procedures for Consolidated Corporations	
	(12) Pre-filing Consultation	
6	Flow of APA Process .....	11
	(1) Submission of APA Request	
	(2) Review of Request by RTB's APA Review Team	
	(3) MAP Negotiations and Agreement	
	(4) Review of Annual Compliance Report, etc.	
	<b>【Chart】</b> Flowchart of BAPA Procedures	
7	Staff in Charge of BAPA Cases .....	14
	(1) Staff in the MAP Office	
	(2) APA Review Groups	
8	Taxpayer's Cooperation in APA .....	16
Reference	Japan's Tax Convention Network	



## 1. Introduction

Transfer pricing taxation was introduced in Japan in 1986. In 1987, Advance Pricing Arrangements (APAs) were initiated, making Japan the first country in the world to implement such a procedure.

The basic mechanism of transfer pricing taxation is to compute the taxable income of a corporation as if its transactions with its foreign-related entity/entities have been conducted at arm's length prices; this is in case the taxable income of the corporation has been reduced as a result of the fact that its transactions with its foreign related entity/entities have not been based on the arm's length principle.

An APA is a framework whereby, based on the application from a taxpayer, the tax administration confirms in advance the method of calculating the arm's length prices for transactions with its foreign-related entity/entities. Further, the tax administration will refrain from applying transfer pricing taxation to the taxpayer if the taxpayer files its tax returns in accordance with the confirmed APA conditions for the years covered by the APA.

There are two types of APA, a unilateral APA and a BAPA (or a multilateral APA). In a unilateral APA, the National Tax Agency (NTA) confirms the method of calculating the arm's length price. In a BAPA (or multilateral APA), the NTA confirms the method of calculating the arm's length price based on an agreement on the method reached with one or more foreign tax authorities under the authority of the mutual agreement procedures (MAP).

The NTA is promoting BAPAs to facilitate the enforcement of transfer pricing regulations, mitigate the administrative burden on corporations, and ensure tax predictability for corporate management. The number of BAPA cases has been increasing in recent years as the Japanese economy has become progressively globalized. In addition, APAs have become more widely recognized among taxpayers.

APA cases make up the majority of MAP cases today; this indicates that there is an increasing need to avoid the risk of double taxation in advance by using an APA.

The number of cases on the renewal of APAs has been rising recently. Moreover, cases involving countries without any experience of BAPAs have appeared, and the geographical area covered by APAs is expanding.

Under these circumstances, we hope that this outline will help improve taxpayers' understanding of APAs.

## 2. What is an Advance Pricing Arrangement (APA)?

As noted above, an APA is a framework whereby the tax administration confirms in advance the method of calculating the arm's length prices for transactions with its foreign-related entity/entities. Also, the tax administration will refrain from applying transfer pricing taxation to the taxpayer if the taxpayer files its tax returns in accordance with the confirmed APA conditions for the years covered by the APA.

The objectives of an APA are to ensure taxpayer's predictability for transfer pricing taxation and to promote the proper and smooth enforcement of taxation. Transfer pricing adjustments can often be large, and examinations on transfer pricing often require that taxpayers spend a long period of time addressing them. It may also take a period of time in the MAP process to resolve double taxation issues resulting from transfer pricing adjustments. Taxpayer's risks related to transfer pricing taxation tend to be high; there is likely to be a significant need for APAs, as they help taxpayers that conduct foreign-related transactions to avoid the burden involved in transfer pricing taxation.

There are two types of APA, a unilateral APA and a BAPA (or a multilateral APA). In a unilateral APA, the NTA confirms the method of calculating the arm's length price. While a unilateral APA does not ensure that the foreign-related entity/entities in other countries will avoid the risk of transfer pricing adjustments being made by foreign tax administrations, it may take a shorter period of time to complete than a BAPA.

By contrast, a BAPA consists of the NTA's confirmation of the method of calculating the arm's length price and an agreement about the method reached with one or more foreign tax authorities under the authority of the MAP. The objectives of a BAPA are to ensure taxpayer's predictability for transfer pricing taxation and avoid the risk of double taxation. With a BAPA, the taxpayer is assured of the legal stability of both tax administrations (or all tax administrations in multilateral cases). This is why many countries, including Japan, use BAPAs.

### Diagram of the BAPA Process

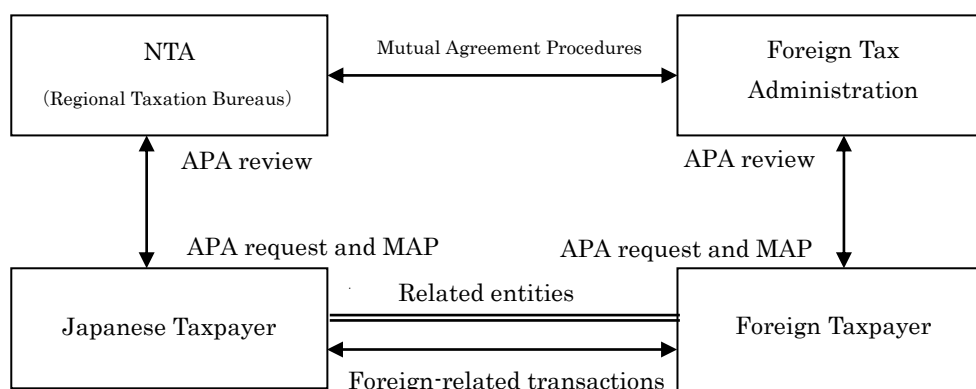

### 3. The History of APAs in Japan and around the World

In the 1980s, the globalization of business activities saw an increasing need to cope with income shifting through foreign-related transactions. Some foreign countries had already prepared to handle such income shifting. Therefore, Japan introduced transfer pricing taxation in March 1986 to realize appropriate international taxation in a common framework with foreign countries.

The APA was introduced in Japan in 1987 to ensure the proper and smooth enforcement of transfer pricing regulations and the predictability of taxation by giving administrative confirmation on the most rational method of calculating the arm's length price.

The United States Internal Revenue Service (IRS) also introduced APAs (known as "Advance Pricing Agreements" in the U.S.) in 1991 through Procedure 91-22. Subsequently, Canada (1994), New Zealand (1994), Australia (1995) and Mexico (1995) also introduced APAs. After the 1995 OECD Guidelines on transfer pricing further promoted APAs, South Korea (1996), China (1998), the U.K. (1999), France (1999), the Netherlands (1999) and Germany (2000) introduced APAs. As such, many countries have now introduced APAs<sup>1</sup>.

Along with this increase in the global recognition of APAs, the number of BAPA requests made in Japan has also increased since 1994. Due to this increase, the *Commissioner's Directive on Methods of Calculation of Arm's Length Prices (Administrative Guidelines)*, encouraging BAPAs, was released in 1999. The contents of these Guidelines have been retained in the succeeding *Commissioner's Directive on the Operation of Transfer Pricing (Administrative Guidelines)*<sup>2</sup> (hereinafter referred to as the "Transfer Pricing Administrative Guidelines") issued on June 1, 2001.

Comprehensive guidelines for MAP, on which BAPA cases are based, were released as the *Commissioner's Directive on Mutual Agreement Procedures (Administrative Guidelines)* (hereinafter referred to as the "MAP Administrative Guidelines") on June 25, 2001<sup>3</sup>. The MAP Administrative Guidelines (provisional English translation) are available on the NTA website ([www.nta.go.jp](http://www.nta.go.jp)).

Countries such as the United States, Canada and Australia also publicize their APA program reports every year on their websites.

---

<sup>1</sup> The OECD issued the OECD/APA Guidelines in 1999, thereby committing to the promotion of BAPAs.

<sup>2</sup> Document ID: Examination Division 7-1 etc., dated June 1, 2001

<sup>3</sup> Document ID: Office of Mutual Agreement Procedures 1-39 etc., dated June 25, 2001  
MAP relating to APAs is regulated in the MAP Administrative Guidelines.

#### 4. International Efforts for Making the MAP Guidance, etc.

In The Pacific Association of Tax Administrators (PATA<sup>4</sup>), the meetings under the Exchange of Information articles of the applicable Convention to exchange opinions about and experiences of fiscal matters of common interest, the tax agencies of Japan, Australia, Canada and the United States released the MAP Guidance and the BAPA Guidance in June 2004. There were to deal with the dramatically increasing use of MAP and BAPAs, and subsequently to respond to the growing demand from taxpayers for international guidance.

Both sets of Guidance establish targets for the execution of MAP and BAPAs among PATA members, but are not binding on the members.

One of the points made in each set of Guidance is to establish a timeframe that the members should endeavor to complete MAP and BAPA cases within two years. This two-year timeframe does not apply to certain cases, such as cases in which a taxpayer does not cooperate. Although MAP is a government-level negotiation, taxpayers that file APA requests are permitted to participate in some sessions to provide factual information.

The MAP Guidance also applies not only to transfer pricing adjustments, but to all mutual agreement procedures.

The BAPA Guidance declares that the member countries cooperate to deal with BAPAs with the common understanding that BAPAs are more desirable than unilateral APAs.

Both sets of Guidance are available on the NTA website ([www.nta.go.jp](http://www.nta.go.jp)).

OECD released the Manual on Effective Mutual Agreement Procedures (MEMAP) in February 2007, as part of a broader project to improve the functioning of existing international tax dispute procedures. This is a guide to increase awareness of the MAP process and function, and will provide basic information on the operation of MAP and identify best practices for MAP. This manual is available on the OECD website ([www.oecd.org/ctp](http://www.oecd.org/ctp)).

(Notes) MEMAP is not imposing a set of binding rules upon OECD member countries.

---

<sup>4</sup> In January 2006, at the commissioners' meeting held at Leeds Castle near London and involving Japan, the United States, Canada, Australia, the United Kingdom, France, China and India, it was agreed to set up a commissioners' meeting (named the "Leeds Castle Group") including the above eight countries, Germany and South Korea. The result of this meeting was the dissolution of PATA.

## 5. Overview of APA in Japan

### (1) Definition of APA<sup>5</sup>

An APA is defined as a confirmation made by a District Director of a Tax Office or a Regional Commissioner of a Regional Taxation Bureau (RTB), with regard to the method deemed most reasonable to be adopted by a corporation of calculating the arm's length price and the specific details thereof.

### (2) Relationship between APA and MAP

#### a. Elimination of double taxation

BAPAs avoid the risk of double taxation in advance, through a BAPA agreement reached between Japan and one or more foreign tax authorities under the authority of the MAP in our income tax treaties.

#### b. Recommendation of MAP request when an APA request is filed<sup>6</sup>

To prevent double taxation and ensure predictability, the RTB's division in charge shall provide a taxpayer who intends to file an APA request with the necessary information enabling the taxpayer to decide what kind of request to make. The division in charge shall also recommend that the APA applicant files a MAP request, if it is confirmed that the applicant intends to execute a BAPA.

#### c. Collaboration between RTB's APA review teams and MAP section<sup>7</sup>

The APA review teams (divisions in charge at RTBs) and the MAP section (Office of Mutual Agreement Procedures of the NTA) shall collaborate and exchange ideas from the pre-filing consultation stage until the conclusion of the MAP, in order to resolve APA cases as quickly as possible.

### (3) Relationship between APA and Transfer Pricing Examination

#### a. Confirmation of method of calculating the arm's length price in future years

An APA is made to confirm the appropriateness of the method of calculating the arm's length price and of the profit level for future transactions based on past financial data, whereas a transfer pricing examination deals with transactions over the past years.

#### b. Use of range

In transfer pricing examinations, an arm's length price is calculated at a particular point. In contrast, an APA often sets a range which satisfies the arm's length principle that does not bring about any income shifting.

---

<sup>5</sup> Transfer Pricing Administrative Guidelines 1-1. Transfer Pricing Administrative Guidelines on Consolidated Corporate Groups (Document ID: Examination Division 7-4 etc. dated 28 April 2005) 1-1

<sup>6</sup> Transfer Pricing Administrative Guidelines 5-12  
Transfer Pricing Administrative Guidelines on Consolidated Corporate Groups 5-12

<sup>7</sup> Transfer Pricing Administrative Guidelines 5-13  
Transfer Pricing Administrative Guidelines on Consolidated Corporate Groups 5-13

c. Comparable transactions

An APA is made to confirm the appropriateness of the method of calculating the arm's length price, and comparable transactions are selected on the basis of information available to the taxpayer (e.g. public data, taxpayer's internal data, etc.).

d. Relationship between an APA request and tax examinations<sup>8</sup>

- It should be noted that examinations are not interrupted as a result of an APA request.
- In order to ensure confidence in the APA system, documents (other than factual documents such as financial statements, capital relationship diagrams, and summary statements of business) received from a corporation for an APA review may not be used for the examination.

**(4) Request and Review Procedures**

a. Due date of filing an APA request<sup>9</sup>

An applicant shall file a "Request for an APA of the Transfer Pricing Methodology" along with the necessary documents no later than the day before the first day of the business year to be covered by the APA<sup>10</sup>. When the applicant requests a MAP, the applicant must also submit an "Application for Mutual Consultation" separately. Although there is no deadline for requesting a MAP in relation to APA cases, the MAP request is usually submitted together with the APA request.

b. Documents to be attached to an APA request<sup>11</sup>

- Documents describing the outline of the foreign-related transactions and the organizations conducting the transactions to be confirmed.
- Documents describing the transfer pricing method (hereinafter referred to as the "TPM") to be confirmed and specific details thereof, and an explanation as to why it is the most reasonable method.
- Documents describing material business and economic conditions essential to the APA
- Documents providing a detailed explanation of the transactions to be confirmed, including cash flow, currencies involved, etc.
- Documents regarding direct or indirect capital relationships or relationships of substantial control between the foreign-related entity/entities pertaining to the transactions to be confirmed and the APA applicant.
- Documents regarding the functions performed by the APA applicant and the applicable foreign-related entity/entities in the transactions to be confirmed.
- Operational and accounting information for the prior three taxable years.

<sup>8</sup> Transfer Pricing Administrative Guidelines 2-22

Transfer Pricing Administrative Guidelines on Consolidated Corporate Groups 2-22

<sup>9</sup> Transfer Pricing Administrative Guidelines 5-2

Transfer Pricing Administrative Guidelines on Consolidated Corporate Groups 5-2

<sup>10</sup> There is a temporary measure for the timing of application of the revised directive on the deadline for filing a request for an APA renewal. (Document ID: Examination Division 7-24, International Operations Division 1-44, Office of Mutual Agreement Procedures 1-98, Corporation Taxation Division 7-9 (Revision), dated Oct 22, 2008)

<sup>11</sup> Transfer Pricing Administrative Guidelines 5-3, 5-4

Transfer Pricing Administrative Guidelines on Consolidated Corporate Groups 5-3, 5-4

- Documents describing any transfer pricing examinations, appeals, lawsuits, etc., involving the foreign-related entity/entities, and details of past taxation in its/their home country/countries.
- Documents describing the results of applying the proposed TPM to the prior three taxable years.
- Other reference documents required for the APA.

c. Taxable years to be confirmed<sup>12</sup>

In principle, three to five taxable years are to be confirmed.

### **(5) Review of APA Request**

The review is carried out based on the following:

- a. Information about the business conditions of the APA applicant and its foreign-related entity/entities, and about the foreign-related transactions
- b. An analysis of the probability of any income transfer being made in past years that constitute the basic data for review
- c. An analysis of the appropriateness of the method of calculating the arm's length price
- d. An analysis of the comparability of the comparable transactions (e.g. the comparability of the items listed below)
  - Types of inventories, nature of services rendered, etc.
  - Stage of transactions
  - Volume of transactions
  - Terms and conditions of the transactions
  - Functions performed and risks assumed by the party/parties concerned
  - Intangible assets
  - Business strategy
  - Timing of market entry
  - Market conditions

### **(6) Effects of APA<sup>13</sup>**

When a taxpayer files its tax returns in compliance with a confirmed APA, the confirmed transactions are treated as having been conducted at the arm's length price. If the taxpayer's income of any past APA period turns out to be less than the appropriate figure calculated using the confirmed TPM, the taxpayer must file an amended tax return for that year. However, no penalties will be imposed under such circumstances.

---

<sup>12</sup> Transfer Pricing Administrative Guidelines 5-7  
Transfer Pricing Administrative Guidelines on Consolidated Corporate Groups 5-7

<sup>13</sup> Transfer Pricing Administrative Guidelines 5-16  
Transfer Pricing Administrative Guidelines on Consolidated Corporate Groups 5-16

**(7) Examination of Compliance Conditions<sup>14</sup>**

A taxpayer who has received an APA confirmation (hereinafter referred to as a “confirmed corporation”) shall be requested to submit reports (hereinafter referred to as “annual compliance reports”) explaining that its declared income is compliant with the APA by the due date of the taxpayer’s final tax return for each year covered by the APA, or during the period specified by the District Director of the Tax Office. The RTB’s division in charge will examine the reports.

**(8) Compensating Adjustments<sup>15</sup>**

In the event that the income (actual figure) derived from confirmed transactions for the years covered by an APA is not compliant with the APA, the taxpayer must make the necessary adjustments (hereinafter referred to as a “compensating adjustment”). If the confirmed corporation makes any adjustments in its financial statements to comply with the APA, the adjustments shall be treated as legitimate transactions for the purpose of transfer pricing.

If it turns out that the income of the confirmed corporation is less than the appropriate figure calculated using the confirmed TPM, one of the two following procedures must be followed:

a. Correction of the taxable income on the final tax return

The confirmed corporation shall correct the taxable income on its final return if it turns out that, after the closing date of the financial statements and before the due date of the final tax return, the income was understated in the financial statements pertaining to the confirmed taxable years due to an inconsistency between an actual transaction and the result of applying the confirmed TPM.

b. Amended return

The confirmed corporation shall promptly file an amended tax return if, after filing the tax return, it turns out that the income was understated in the tax return pertaining to a confirmed taxable year due to an inconsistency between an actual transaction and the result of applying the confirmed TPM.

If it turns out that the income of the confirmed corporation is more than the appropriate figure calculated using the confirmed TPM, the confirmed corporation may adjust its income in one of the following two ways:

a. Correction of the taxable income on the final tax return

The confirmed corporation may correct the taxable income on the final tax return based on the mutual agreement concerning compensating adjustments if it turns out that, after the closing date for the financial statements and before filing the final tax return, the income in the financial statements pertaining to a confirmed taxable year was overstated due to an

---

<sup>14</sup> Transfer Pricing Administrative Guidelines 5–18

Transfer Pricing Administrative Guidelines on Consolidated Corporate Groups 5–18

<sup>15</sup> Transfer Pricing Administrative Guidelines 5–19

Transfer Pricing Administrative Guidelines on Consolidated Corporate Groups 5–19



inconsistency between an actual transaction and the result of applying the confirmed transfer pricing method.

b. Request for correction

The confirmed corporation may file a request for correction based on the mutual agreement concerning compensating adjustments, if it turns out that the income was overstated due to an inconsistency between an actual transaction and the result of applying the confirmed TPM in the tax returns after its final tax returns pertaining to the confirmed taxable years are filed.

## **(9) Revision, Cancellation and Renewal of APA**

a. Revision<sup>16</sup>

In cases where there is a situation that causes a material difference to business and economic conditions essential to the continuation of the APA, the taxpayer shall file a request for an APA revision.

b. Cancellation<sup>17</sup>

An APA shall be cancelled under any of the following circumstances:

- The confirmed corporation has not submitted a request for revision even when a material difference in critical assumptions necessary to continue the APA has arisen.
- The confirmed corporation has failed to comply with the APA in its tax return.
- The confirmed corporation has failed to submit an annual compliance report, or the report contains any material error.
- Any of the facts on which the APA request is based are revealed to be false, or the APA request contains a material error.

c. Renewal<sup>18</sup>

In cases where a confirmed corporation files a request for renewal of its APA for business years following the confirmed years, the request shall be processed in accordance with the procedures for a new APA request.

## **(10) Rollback<sup>19</sup>**

When a taxpayer requests “rollback” treatment (i.e. retrospective application) of the TPM to the years prior to the APA period, and the TPM confirmed in the BAPA is regarded as the most appropriate TPM for the years prior to the APA period, the rollback may be permitted.

---

<sup>16</sup> Transfer Pricing Administrative Guidelines 5–20

Transfer Pricing Administrative Guidelines on Consolidated Corporate Groups 5–20

<sup>17</sup> Transfer Pricing Administrative Guidelines 5–21

Transfer Pricing Administrative Guidelines on Consolidated Corporate Groups 5–21

<sup>18</sup> Transfer Pricing Administrative Guidelines 5–22

Transfer Pricing Administrative Guidelines on Consolidated Corporate Groups 5–22

<sup>19</sup> Transfer Pricing Administrative Guidelines 5–23

Transfer Pricing Administrative Guidelines on Consolidated Corporate Groups 5–23

**(11) Procedures for Consolidated Corporations**

The NTA established the Commissioner's Directive on the Operation of Transfer Pricing Related to Consolidated Corporate Groups in April 2005.<sup>20</sup> The parent corporation shall file an APA request concerning its own transactions with foreign-related entities in the name of the parent corporation with the District Director of the Tax Office, with jurisdiction over the place where it pays its tax. The parent corporation, instead of its subsidiary, shall also file an APA request concerning the foreign-related transactions of the consolidated subsidiary with the District Director of the Tax Office, with jurisdiction over the place where it pays its tax<sup>21</sup>.

The Commissioner's Directive on Mutual Agreement Procedures (Administrative Guidelines) was also revised to designate the consolidated parent corporation as the entity required to file a MAP request on behalf of its subsidiaries.<sup>22</sup>

**(12) Pre-filing Consultation<sup>23</sup>**

A Pre-filing Consultation is defined as a consultation held prior to an APA request (including anonymous consultations conducted through an agent) made by the corporation seeking to receive the confirmation from the RTB's division in charge (including, where necessary, the NTA's division in charge and the Office of Mutual Agreement Procedures) concerning the TPM.

Through a Pre-filing Consultation, both the taxpayer and the APA team can establish a common basic understanding on the APA request. In doing so, it is expected that effects such as a reduction in the taxpayer's burden to prepare necessary documents and facilitation of the review conducted by the RTB's APA team will be brought about, as a result of which the APA teams offer advice at pre-filing consultations in consideration of the following points:

- Explaining necessary matters on APA procedures (e.g., how to prepare the APA request and its attachments, the due date of filing, etc.).
- Understanding the details of foreign-related transactions on which advice is sought and providing the taxpayer with the necessary information to make an appropriate decision as to whether or not to apply for an APA, and what kind of request to make.

---

<sup>20</sup> See footnote 5.

<sup>21</sup> Transfer Pricing Administrative Guidelines on Consolidated Corporate Groups 5-1

<sup>22</sup> Document ID: Office of Mutual Agreement Procedures 1-18 etc. dated June 8, 2005 (amended)

<sup>23</sup> Transfer Pricing Administrative Guidelines 1-1, 5-10

Transfer Pricing Administrative Guidelines on Consolidated Corporate Groups 1-1, 5-10

## 6. Flow of APA Process

In Japan, an APA commences with the request of the taxpayer. The NTA does not charge any fee for APA proceedings. BAPA procedures, as a rule, can be divided into the following four steps: (1) submission of an APA request, (2) review of the request by the RTB's APA review team, (3) MAP negotiations and agreements, and (4) review of annual compliance reports, etc.

### (1) Submission of APA Request

The taxpayer may have a pre-filing consultation with the tax authority before deciding whether to apply for an APA.<sup>24</sup> Where a MAP is likely to be requested at a later date, the MAP Office of the NTA may participate in the consultation, in addition to the relevant divisions of the RTB and of the NTA in charge of the APA. Further, there may be cases where the taxpayer applies for an APA, after a transfer pricing examination that resulted in a transfer pricing adjustment, in order to avoid the risk of being taxed in the future and ensure tax predictability for its business. In such a case, if a MAP is under way regarding the former transfer pricing adjustment case, the taxpayer can submit an APA request to the MAP Office and then arrange for a pre-filing consultation.

In cases where an applicant for an APA has not filed a MAP request, the NTA recommends that the applicant file a MAP request if it is confirmed that the taxpayer intends to do so<sup>25</sup>.

APA requests are submitted to the Tax Office or the RTB. The taxpayer is required to attach the necessary documents (see 5(4)b) to the request form for the purpose of facilitating the review of APA requests by the RTB's APA review team.

### (2) Review of Request by the RTB's APA Review Team

When the APA request is submitted, the relevant division of the RTB designates a tax examiner in charge of the request and commences the review immediately. The APA review staff designates request documents required for the review in addition to the documents attached to the APA request. The RTB's APA review team then reports the results of its review to the division in charge at the NTA. The NTA's division reviews the report internally and sends it to the MAP Office.

The RTB's APA review team conducts its review in accordance with the Transfer Pricing Administrative Guidelines 5-11 (Review of APA Requests).

---

<sup>24</sup> Transfer Pricing Administrative Guidelines 5-10  
Transfer Pricing Administrative Guidelines on Consolidated Corporate Groups 5-10

<sup>25</sup> Transfer Pricing Administrative Guidelines 5-12  
Transfer Pricing Administrative Guidelines on Consolidated Corporate Groups 5-12

**(3) MAP Negotiations and Agreements<sup>26</sup>**

In the case of a BAPA, a CA analyst drafts a position paper based on the conclusion reached in the APA review by the RTB's APA review team. Face-to-face negotiations between the CA staff of the tax agencies of the countries concerned are generally held several times a year. In addition, CAs exchange views by telephone, fax, and other means. The CA staff and the APA review staff also exchange views based on the circumstances of the MAP to confirm material facts.

When an APA agreement with terms the same as those of the original APA request is reached, the RTB's APA review team sends a notice of APA confirmation to the taxpayer. When an APA agreement with terms different from those of the original APA request is reached, the taxpayer is required to submit a modified APA request in accordance with the agreement. The RTB's APA review team then sends a notice of APA confirmation to the taxpayer.<sup>27</sup>

**(4) Review of Annual Compliance Report etc.<sup>28</sup>**

After the APA confirmation notice is received, the taxpayer is required to submit, by the due date of its final tax return or by another designated date, the annual compliance report that explains whether or not the business results reported in the year's tax return accord with the agreement. The RTB's division in charge, if necessary, may request a further explanation from the taxpayer and also visit the taxpayer for review. In cases where income figures are lower than the figures agreed, they must be adjusted to the figures agreed in the amended tax return. Reviews of Annual Compliance Reports carried out by the RTB's division in charge correspond to tax examinations for corporation tax. Conversely, in cases where income figures are higher than the figures agreed, MAP negotiations must be held. The taxpayer must submit a MAP request and make a compensating adjustment (request for correction of tax return for downward adjustment) based on the new MAP agreement.

When the conditions provided in critical assumptions change, the taxpayer must submit a new MAP request.

---

<sup>26</sup> Transfer Pricing Administrative Guidelines 5–13

Transfer Pricing Administrative Guidelines on Consolidated Corporate Groups 5–13

<sup>27</sup> In the case of a unilateral APA, a modified APA request may be requested when the RTB's APA review group judges the original APA request to be unreasonable. If the taxpayer does not accept the request for modification from the APA review group, the APA review group sends a notice of non-confirmation. When the content of the APA request is approved, or when the taxpayer accepts the required modification, the RTB's APA review group sends a notice of confirmation to the taxpayer.

<sup>28</sup> Transfer Pricing Administrative Guidelines 5–17, 5–18

Transfer Pricing Administrative Guidelines on Consolidated Corporate Groups 5–17, 5–18

### Flowchart of BAPA Procedures

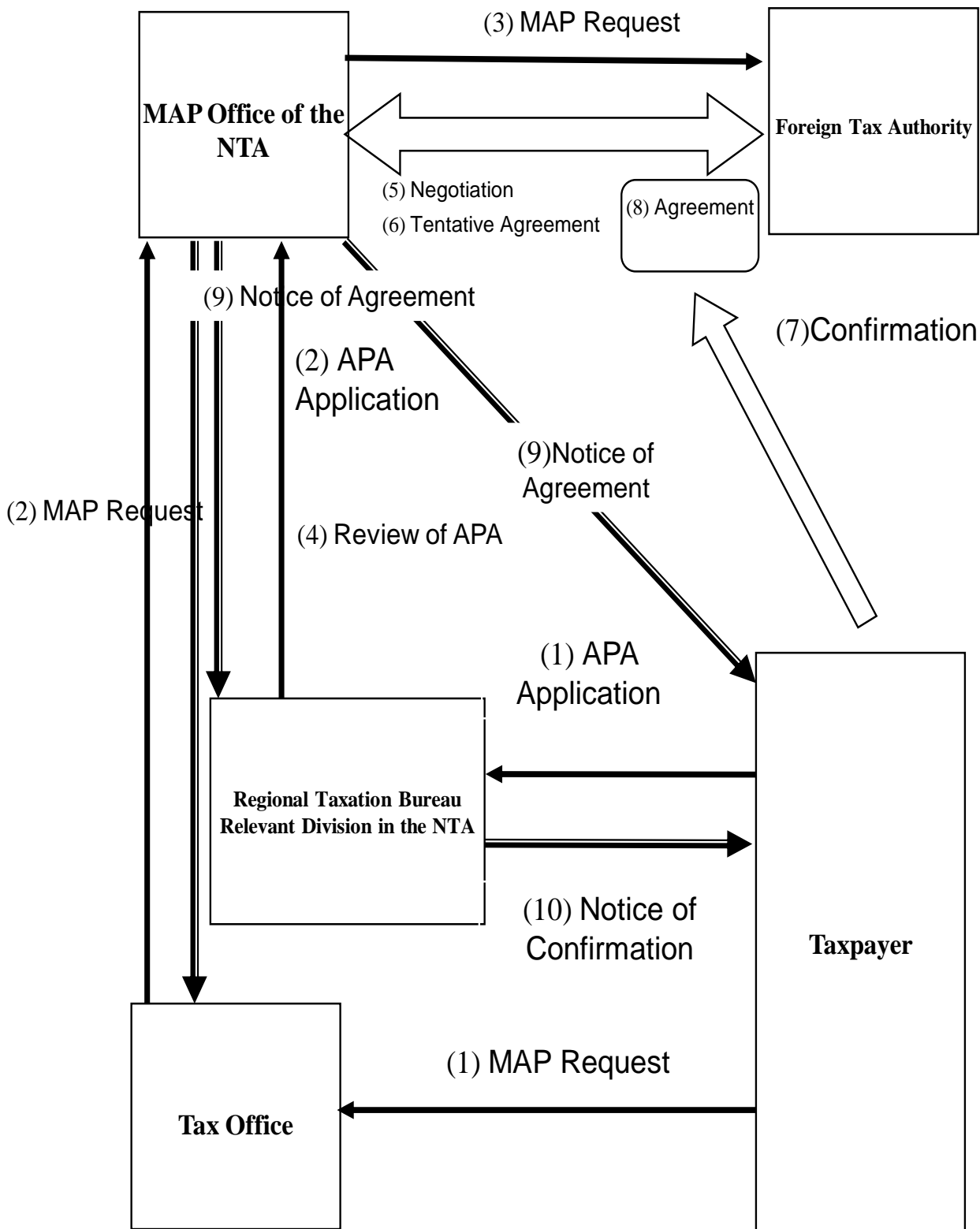

## 7. Staff in Charge of BAPA Cases

### (1) Staff in the MAP Office

A section in charge of MAP was created in June 1982 and initially placed under the Councilor of the Minister's Secretariat (Deputy Commissioner [International Affairs]) and the Director (Office for the Deputy Commissioner [International Affairs]), who dealt with international conferences and mutual agreement procedures. The Office of International Operations was established in 1986. Subsequently, the position of the Director responsible for MAP cases was created in 1995. The Office of Mutual Agreement Procedures was established in July 1999. One more director post mainly responsible for APAs was created in July 2008.

The staff of the Office of Mutual Agreement Procedures are responsible for all MAP cases; they handle not only BAPA cases, but also transfer pricing taxation cases, withholding cases, permanent establishment cases, etc. The table below describes the current structure of the Office of Mutual Agreement Procedures.

Deputy Commissioner (International Affairs)	Director, Office of Mutual Agreement Procedures	Group	Jurisdiction
		1-a	Mainly North America, Asia and Oceania
1-b			
2-a			
2-b			
Director (Mutual Agreement Procedures)	APA1	Mainly North America (APA)	
	APA2		
Director (Mutual Agreement Procedures)	3-a	Mainly Western Europe	
	3-b		

### (2) APA Review Groups

The Large Enterprise Examination Division of the Large Enterprise Examination and Criminal Investigation Department of the NTA established the post of Director (International Examination) and Transfer Pricing Section No. 1-3 in 1987. They supervise and guide transfer pricing taxation and the APA of each RTB.

National Tax Agency			
Deputy Commissioner (Large Enterprise Examination and Criminal Investigation)	Director, Large Enterprise Examination Division	Director (International Examination)	Transfer Pricing Section No. 1-3

The table below describes the current structure of the RTB.

Regional Taxation Bureau (Office)			
Tokyo RTB	First Large Enterprise Examination Department	Deputy Assistant Regional Commissioner (International)	Advance Pricing Arrangement Division
Osaka RTB	First Large Enterprise Examination Department		Advance Pricing Arrangement Division
Nagoya RTB	Large Enterprise Examination Department		International Examination of Large Enterprise Division
Kantoshinetsu RTB	Large Enterprise Examination and Criminal Investigation Department		International Examination of Large Enterprise Division
Other RTBs	Large Enterprise Examination and Criminal Investigation Department		Management Division (Large Enterprise Examination)
Okinawa Regional Taxation Office			Large Enterprise Examination Division

## 8. Taxpayer's Cooperation in APA

The APA system is based on the voluntary applications of taxpayers. The taxpayer's cooperation with the review of an APA request is therefore indispensable to its proceeding smoothly. In particular, timely submission of relevant documents and other information significantly contributes to efficient reviews and MAP processes. Prompt submission is therefore essential.

Furthermore, when an APA request is submitted to a foreign tax administration, the APA application should be submitted simultaneously to the NTA, in order to enable a more effective case review and BAPA negotiations.

Even after the commencement of the MAP process, CA analysts often request additional information for the purpose of, for example, verifying facts. On such occasions, the taxpayer's prompt response is highly appreciated.



# Japan's Tax Convention Network

(Reference)

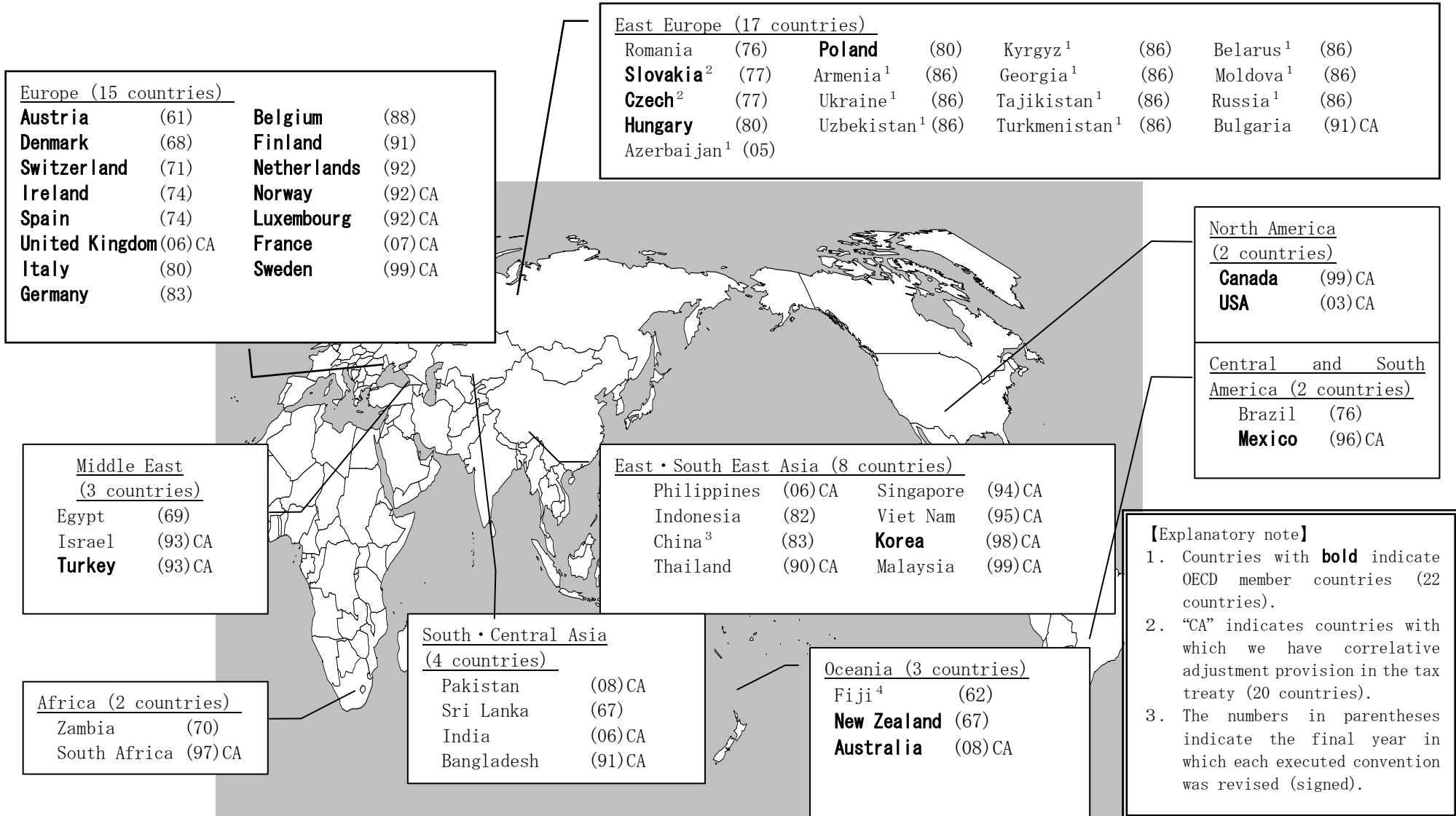

**【Explanatory note】**

1. Countries with **bold** indicate OECD member countries (22 countries).
2. "CA" indicates countries with which we have correlative adjustment provision in the tax treaty (20 countries).
3. The numbers in parentheses indicate the final year in which each executed convention was revised (signed).

NOTICE- 1. The former Japan-Soviet Union convention is inherited.  
 2. The former Japan-Czechoslovakia convention is inherited.  
 3. This convention is not applicable to Hong Kong or Macau.  
 4. The former Japan-U.K. convention is inherited.